

PCS-210KW Energy Storage Cabinet

User Manual

Table of Contents

1 Product Introduction	4
1.1 System Introduction	4
1.2 PCS Appearance	4
1.3 System Schematic Diagram	5
1.4 PCS Composition	5
1.5 Operating Compositions	6
1.5.1 Switches Introduction	6
1.5.2 Port type and configuration of PCS module.....	8
2 Technical Data	11
3 Storing, lifting and transporting.....	12
3.1 Safety during Transport.....	12
3.2 Transporting the PCS.....	13
3.2.1 Transport and storage.....	13
3.3 Unpacking the PCS.....	13
4 Installation	13
4.1 Safety during Installation.....	13
4.2 Mechanical Installation.....	14
4.2.1 Mounting preparation.....	14
4.2.2 Preparation for Mounting on a Base	17
5 Contact.....	17

1 Product Introduction

1.1 System Introduction

The PCS-210KW Energy Storage Cabinet(PCS) is a battery power conversion system that converts the DC (direct current) supplied by a battery into grid-compliant AC (alternating current). An [external] low voltage transformer fitted downstream feeds the AC (alternating current) into the utility grid.

This kind of PCS can be used in the on-grid mode and off-grid mode. The model with STS can get the faster switching between on-grid and off-grid mode.

The PCS-210KW Energy Storage Cabinet(PCS)] can be used in off-grid systems based on diesel generators (Gensets).

1.2 PCS Appearance

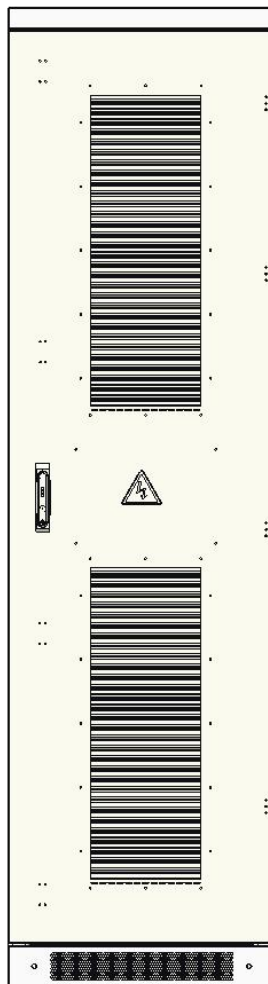

Figure 1-1 : Design of the PCS

1.3 System Schematic Diagram

PCS-210KW PCS-210KW Energy Storage Cabinet(PCS) is composed of 2 PCS-AC modules. The modules identify master-slave systems through the DIP switch dial-up codes on the

panel. #1 is a master system, while other modules track the master system. The PCS-210KW Energy Storage Cabinet(PCS) cabinet is equipped with SPD protector, AC/DC breaker and distribution units. If on/off-grid switching is to be achieved, extra power distribution unit needs to be added. Fig.1-2 is a topological graph for its composition and structure.

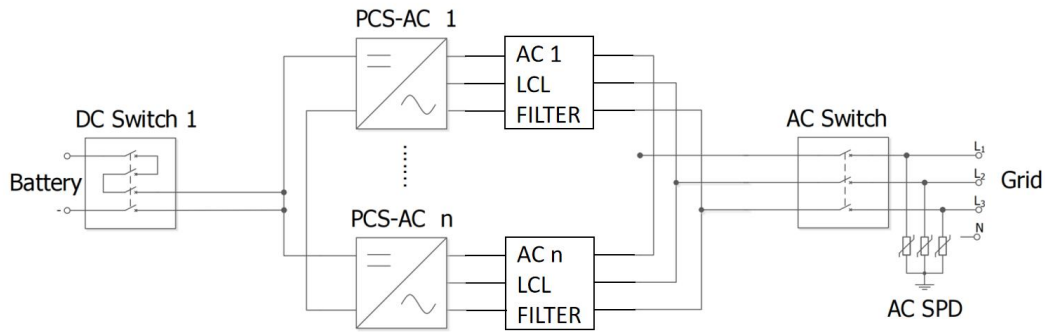

Fig. 1-2 Topological graph for PCS-210KW Energy Storage Cabinet(PCS) with 1 branch input

1.4 PCS Composition

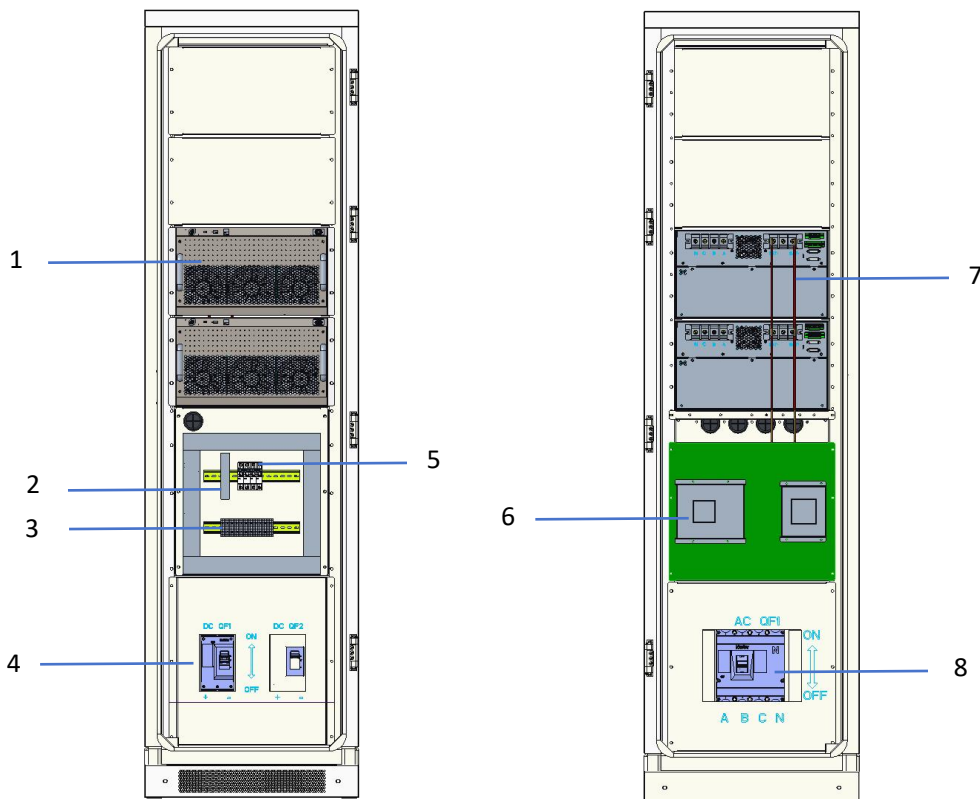

Figure 1-3 : Visible Components of the PCS without STS module

Position	Designation	Description
1	PCS-AC (1~2 module(s))	105KW 1 set

2	Exchange	
3	Wiring terminal	
4	Battery DC Branch Switch	1 to 2 set DC Branch Switch
5	AUX Power supply switch	
6	Main control board	
7	Parallel copper bar	
8	AC Switch	

1.5 Operating Compositions

1.5.1 Switches Introduction

1.5.1.1 AC switch

The AC disconnection unit disconnects the PCS from the Grid. The NA series PCS breaker is comply to the CE/UL certification.

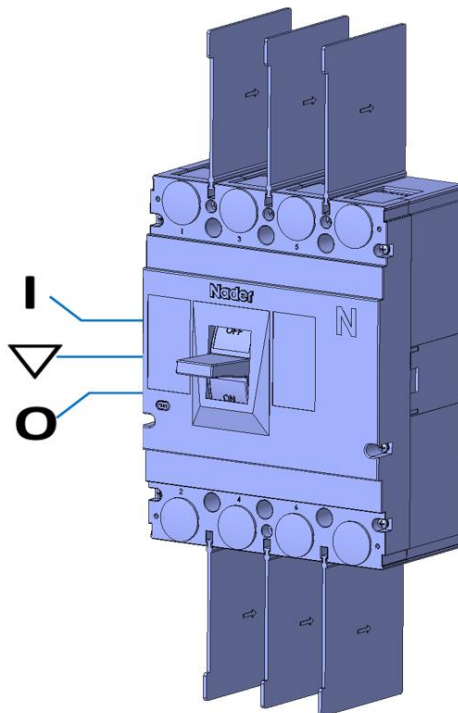

Figure 1-4 : Switch positions of the AC disconnection unit

Position	Designation	Description
I	Switch position In (On)	The AC disconnection unit is closed.
∇	Central switch position	The AC disconnection unit was tripped and is open.
O	Switch position off	The AC disconnection unit is open.

1.5.1.2 DC Switch

The DC disconnection unit disconnects the PCS from the Battery module arrays. The NA series PCS breaker is comply to the CE/UL certification.

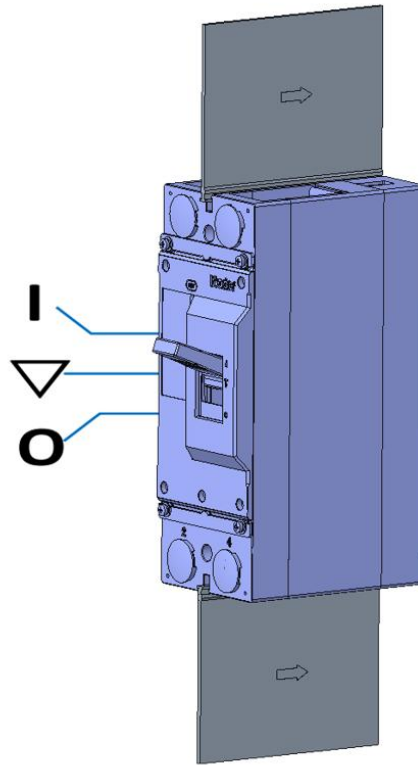

Figure 1-5: Indicators on the DC load-break switch

Position	Designation	Description
I	Switch position In (On)	The DC disconnection unit is closed.
∇	Central switch position	The DC disconnection unit was tripped and is open.
O	Switch position off	The DC disconnection unit is open.

1.5.2 Port type and configuration of PCS module

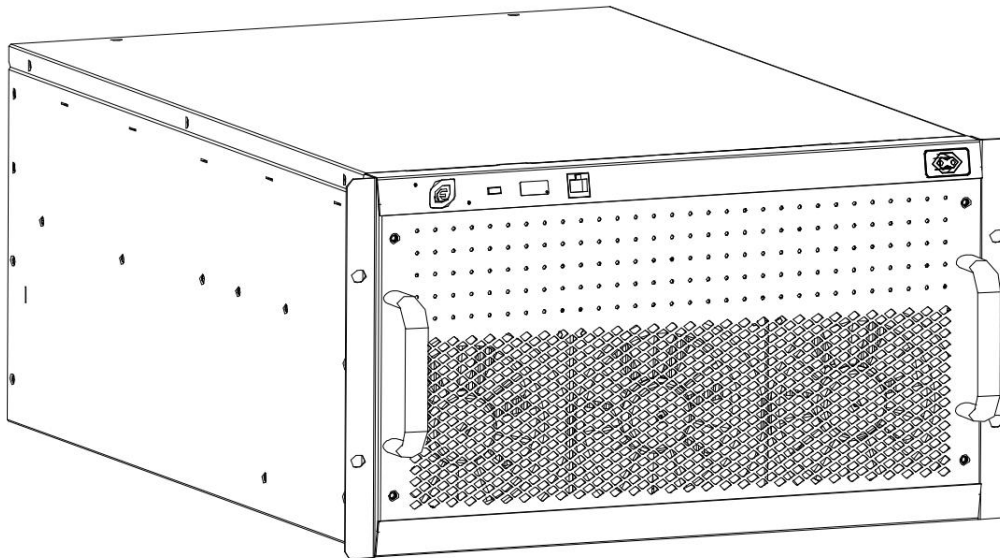

Figure 1-6 :105KW-PCS schematic diagram (after maintenance)

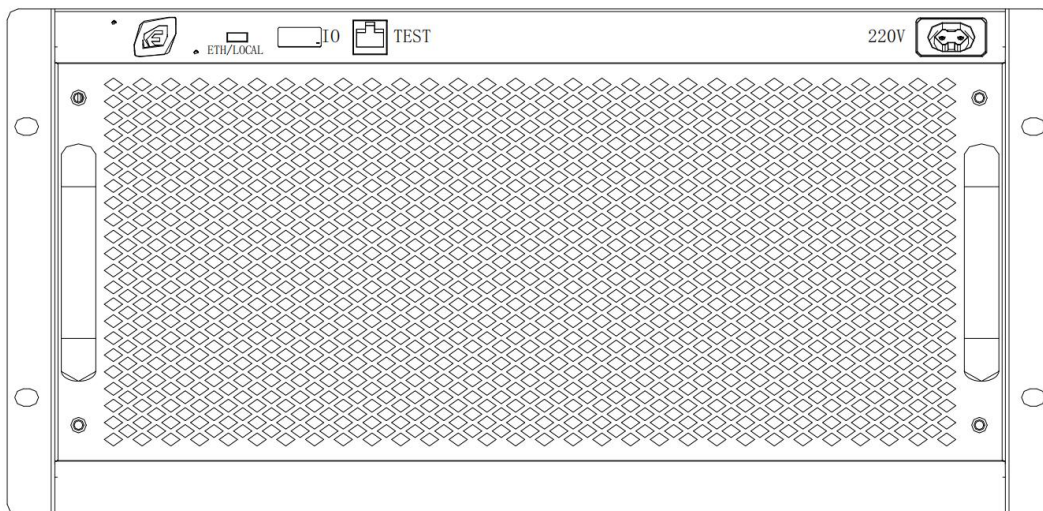

Figure 1-7 : Front view for PCS-AC module

No.	Designation	Description
1	ETH/LOCAL	Remote/local switch, right dial for background debugging (default right dial)
2	(IO) 6-bit DIP switch	1-2 bits for CAN communication matching resistance access;3-6 Setting the module Address (binary)
3	TEST	Factory debugging communication port (internal only)
4	220V	220V AC input (internal only)

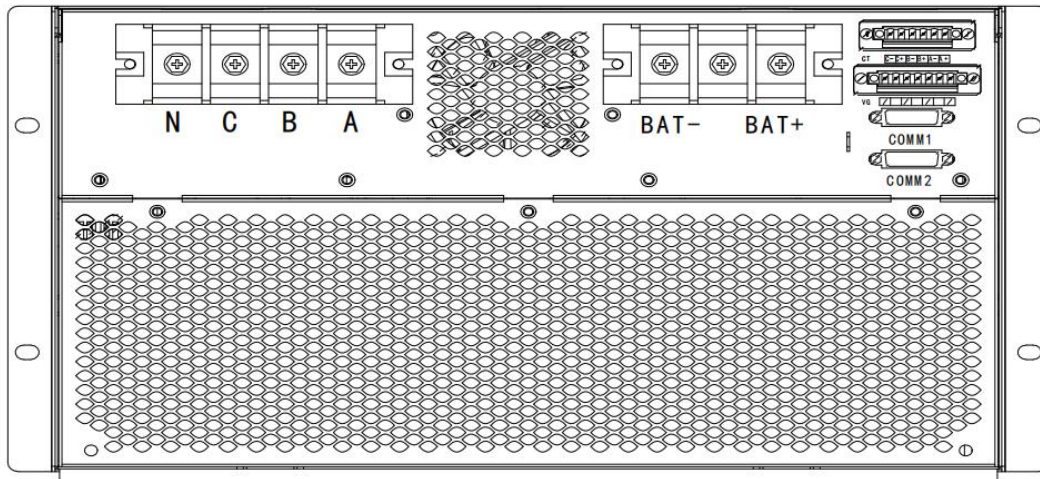

Figure 1-8 : Rear view for PCS-AC module

PCS power port diagram & description sheet

Terminal symbol	Terminal function description
BAT+	DC positive terminal
BAT-	DC negative terminal
A	Phase A input
B	Phase B input
C	Phase N input
N	Three-phase four-wire system center line input

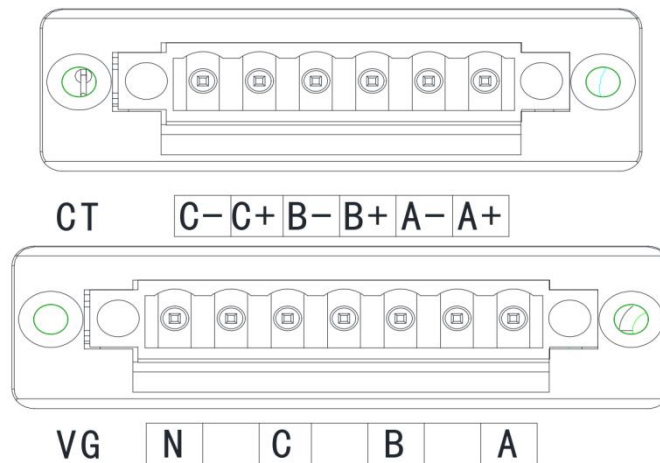
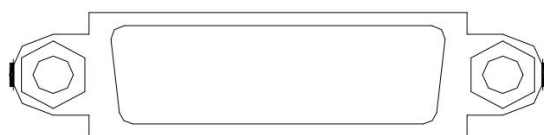

Figure 1-9 : Signal port 1 of the PCS-AC module

Name	Terminal symbol	Terminal function description
------	-----------------	-------------------------------

Grid Current Sampling Interface (CT)	A+	Wire the S1 port of the A-phase CT
	A-	Wire the S2 port of the A-phase CT
	B+	Wire the S1 port of the B-phase CT
	B-	Wire the S2 port of the B-phase CT
	C+	Wire the S1 port of the C-phase CT
	C-	Wire the S2 port of the C-phase CT
Grid Voltage Sampling Interface (VG)	A	Phase A grid voltage sampling input
	NC	No wiring
	B	Phase B grid voltage sampling input
	NC	No wiring
	C	Phase C grid voltage sampling input
	NC	No wiring
	N	Phase N grid voltage sampling input



COM1



COM2

Figure 1-10 : Signal port 2 of the PCS-AC module

COM (26pin signal terminal) signal port details

Name	Pin number	Name	Pin number	Function description
BMS_485A	10	BMS_485B	19	485 communication is used to connect to the EMS/ PC
HMI_485A	1	HMI_485B	11	485 Communication for HMI monitoring
ETH_485A	20	ETH_485B	2	485 Communication (Standby)
CAN1L	12	CAN1H	21	Parallel CAN communication
CAN2L	3	CAN2H	13	BMS_CAN

				communication
INV-SYNC-ISO	4	CARRIER_SYNC	22	Synchronization signal
GND_ ISO1	14	GND_ ISO2	23	Signal common terminal
24V_ ISO_SYS1	5	24V_ ISO_SYS2	15	DC24V output
LED_ FLT_ ISO	6	LED_RUN_ ISO	24	LED signal failure/operation signal
SPD_ALARM-ISO	16	FIRE_ALARM-ISO	25	Lightning protection/fire alarm input
DI1_ ISO	7	DI2_ ISO	17	DI1/DI2 Indicates the number of digits
DO_ ISO	8	EPO_ ISO	26	DO1 Digital quantity /EPO input
OP	18	GND_ ISO4	9	DI Type selection /DO Output ground Point (STS standby)

2 Technical Data

Input/output parameter list (including protection features)

DC side	
Voltage range (V)	615 ~ 950 (3P3L) /680 ~ 950 (3P4L)
Number of input circuits	1
Maximum charge and discharge current (A)	340
AC side(on-grid)	
Rated voltage (V)	230/400
Wiring mode	3P3L/3P4L
Rated output power (KW)	210
Maximum apparent power (kVA)	231
Maximum current (A)	334
Rated frequency of the grid (Hz)	50/60
Power factor	>0.99
Power factor range	-1~1
Current distortion rate	<3%(Rated power)
DC component	0.5%
Overload capability	110%(long-term)
Peak efficiency	98.2%
AC side(off-grid)	
Rated voltage (V)	230/400
AC voltage harmonics	<3%(Linear load)
Rated frequency (Hz)	50/60
Rated output power (KW)	210
Maximum apparent power (kVA)	231
Maximum output current (A)	334

Protection	
Have function	OTP, AC OVP/UVP, OFP/UFP, EPO, AC Phase Reverse, Fan/Relay Failure, OLP, GFDI, Anti-islanding
System parameter	
Size (W× D× H)	624×1150×2300mm
Max elevation	4000m(> 2000m derating)
Operating ambient temperature	-30°C ~ 55°C (De-rating over 45°C)
Storage ambient temperature	-45°C ~ 70°C
Humidity	0%RH~95%RH (No condensing)
Cooling mode	Intelligent air cooling
Enclosure	IP54
Communication	RS485/CAN

3 Storing, lifting and transporting

More detailed shipping and installation information can be found in the Installation Manual.

3.1 Safety during Transport



WARNING

If the lifted or suspended load falls over, falls or sways, there is a risk of crushing. Vibration or careless or hasty lifting and transport can cause the product to tip over or fall. This can result in death or serious injury.

All national transport standards and regulations must be respected.

Always transport the product as close as possible to the floor.

Avoid fast or uneven movement during transport.

Always maintain a sufficient safety distance from the product during transportation.



NOTICE

Damaged frame structure of the PCS due to uneven support surface

Placing the PCS on an uneven surface can cause bending, which causes the PCS door to no longer close

properly. This can cause moisture and dust to seep into the PCS.

Do not place the PCS on an unstable, uneven surface, even for short periods of time.

The unevenness of the support surface must be less than 0.25%.

Do not use the installed kick plate to transport the PCS.

3.2 Transporting the PCS

3.2.1 Transport and storage

The module of the PCS are installed in the PCS cabinet rack during shipping. During device transport and storage, pay attention to the caution sign on the packing case.

The selection of storing position should ensure that:

- There is no corrosive gas around it.
- There are over-wetting and high-temperature sources.
- It is not a dusty environment.
- It complies with the local firefighting requirements.



NOTICE

During rack transport and storage, stacking is not allowed. The device top cannot be placed with other articles.

The rack should be placed vertically at forward direction. Don't keep it upright placed horizontally.

4 Installation

Installation tool preparation



safety gloves



protection goggle



safety shoes



protective suit



torque screwdriver



wire strippers



hydraulic pliers



heat gun



multimeter



screwdriver



torque wrench

4.1 Safety during Installation



DANGER

Risk of electric shock caused by live voltage

There is a high voltage in the live components of the product. Touching field components can result in death or seriousness electric shock damage.

Wear appropriate personal protective equipment for all work on the product.

Do not touch any live components.
Observe all warning messages in products and documents.
Obey all safety information from the battery manufacturer.



Electric shock hazard caused by DC cable
The DC cable connected to the battery is live. Contact with live cables can cause electrocuted death or serious injury shock.
Before connecting the DC cable, make sure that the DC cable has no voltage.
Wear appropriate personal protective equipment for all work on the product.



Danger to life due to electric shock when entering the storage system
Damage to the insulation in the storage system can result in fatal ground currents. May cause a fatal electric shock. Ensure that the insulation resistance of the storage system exceeds the minimum.
Minimum value: The insulation resistance is: 14kΩ.
The PCS must be installed in a closed electrical operating area.



Fire due to failure to observe torque specifications at real-time bolt connections
Failure to comply with the specified torque reduces the current carrying capacity of the live bolt connection, thereby reducing the contact resistance increase.
This can cause the components to overheat and catch fire.
Be sure to always tighten the live bolt connection using the exact torque specified in this document.
Use only the right tools when working on the device.
Avoid repeatedly tightening the live bolt connection as this may result in unacceptably high torque.

4.2 Mechanical Installation

4.2.1 Mounting preparation

Drilling Mounting Holes is required in the Foundation. The overall dimension of the PCS is shown in figure below.

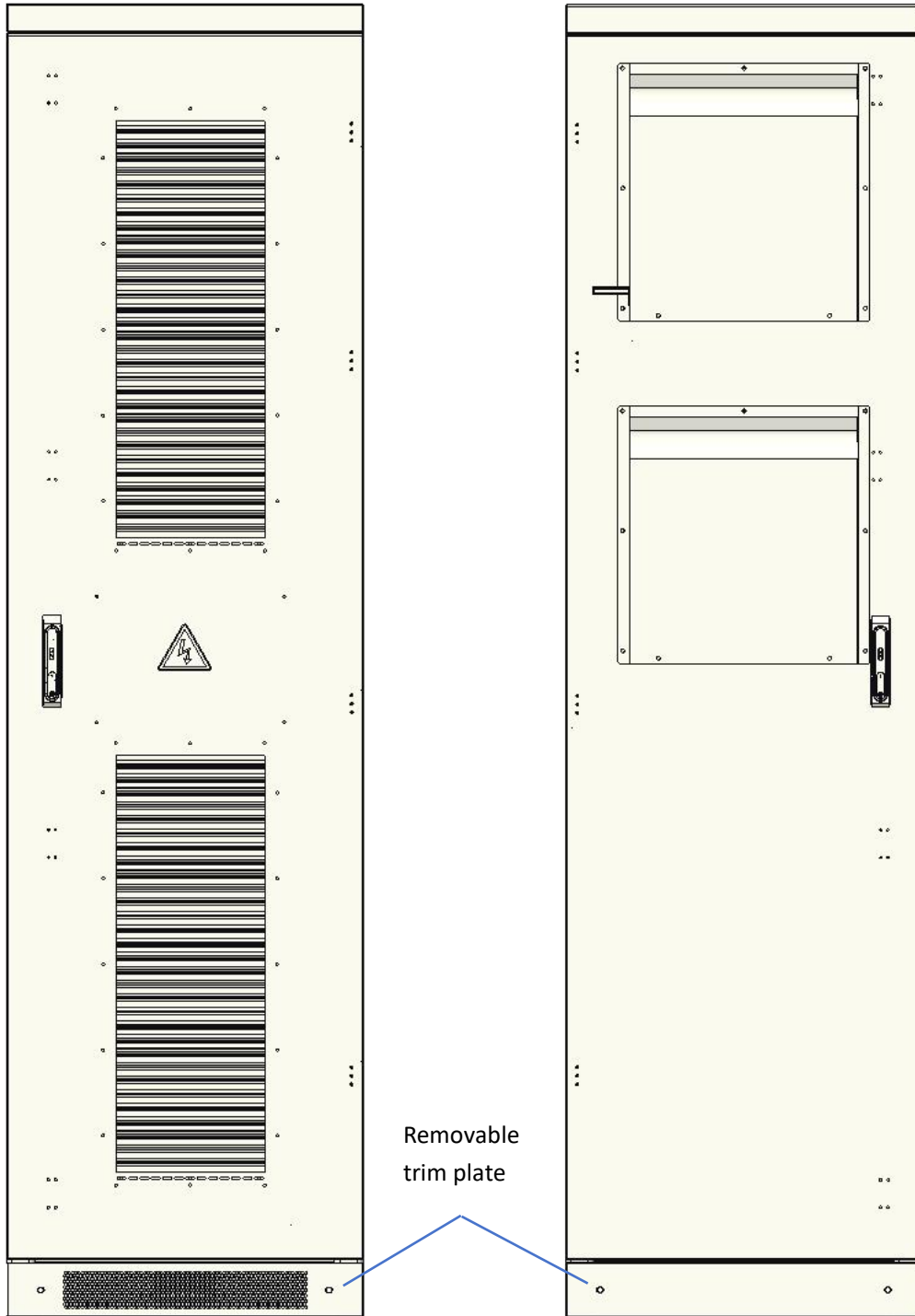

Fig. 4-1 Overall dimensions of PCS

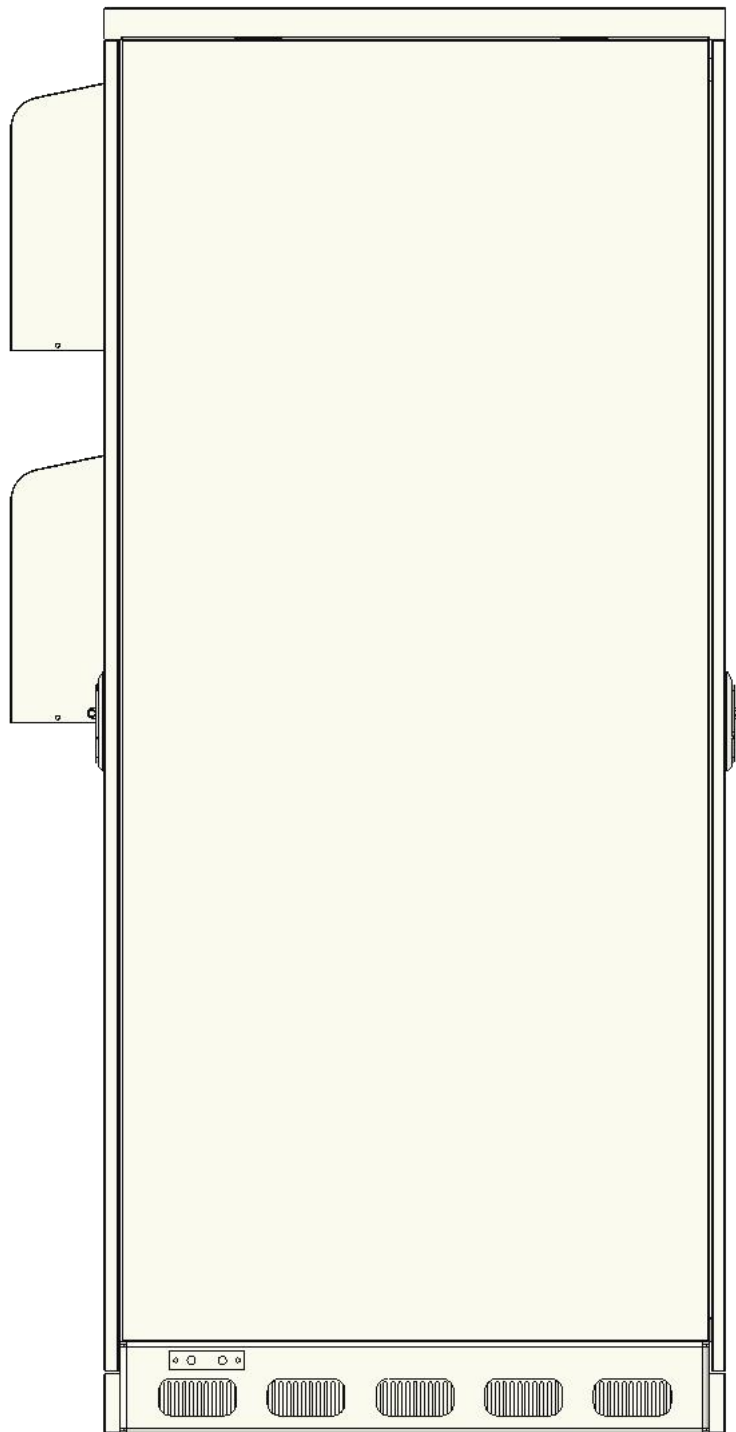

Fig. 4-2 Overall dimensions of PCS

The PCS-210KW PCS cabinet, width: 624mm, depth: 1,150mm,height: 2,300mm.

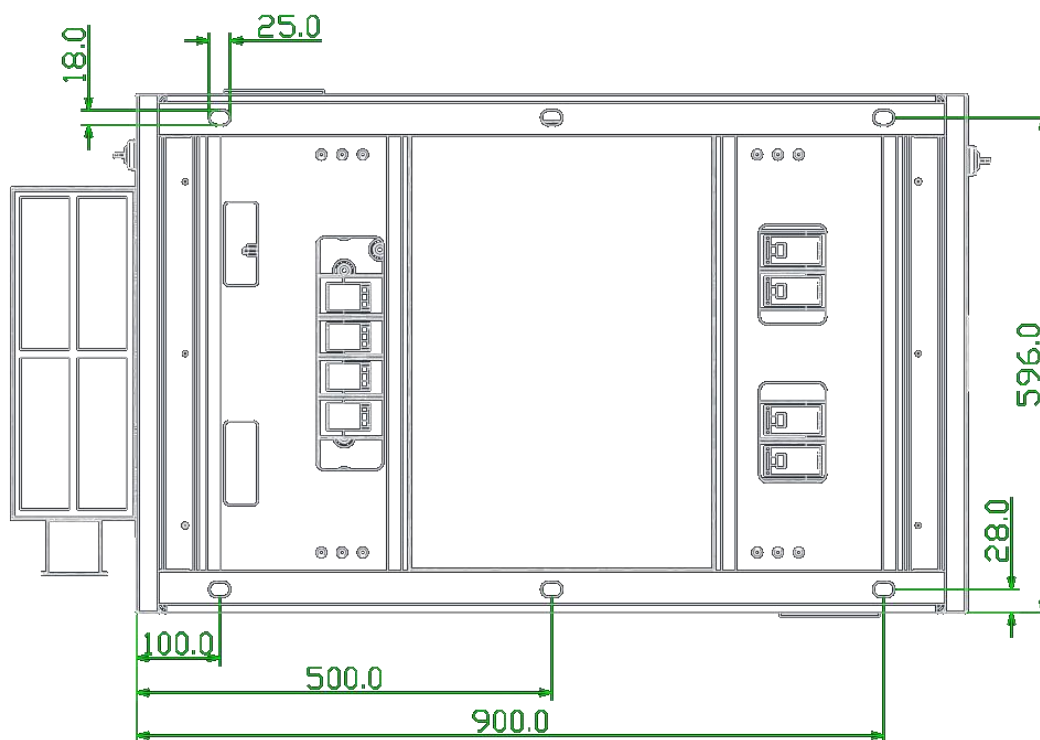

Fig. 4-3 PCS-210KW rack wiring hole in bottom view

4.2.2 Preparation for Mounting on a Base

Remove the base trim. After the rack is removed to the installation position of BESS (battery energy storage system) with a forklift or a tool. Fine adjust the rack and remove it to the designed position, open the internal door of rack, use M14 or M16 screw to fix the rack.

When the rack needs to be fixed on the steel channel, $\Phi 18$ holes can be made in the steel channel. Fix the rack to the steel channel with M16 screws and M16 nuts.

When the rack is fixed to the concrete floor, make holes on the floor and fix the rack to the concrete floor with expansion screws.

For the detailed mounting on a base, please see the Installation Manual.

5 Contact

If you have technical problems with our products, please contact the service hotline.

Please provide the following information to help you with the necessary assistance:

- Equipment model
- serial number
- Battery Type and number
- Communication type
- Firmware version
- Error number and error message

GUANGZHOU RENEPOLY ENERGY TECHNOLOGY CO., LTD.

Website: www.renepoly.com